

DIMENSIONS IN MILLIMETRES
(DIMENSIONS IN FEET-INCHES)

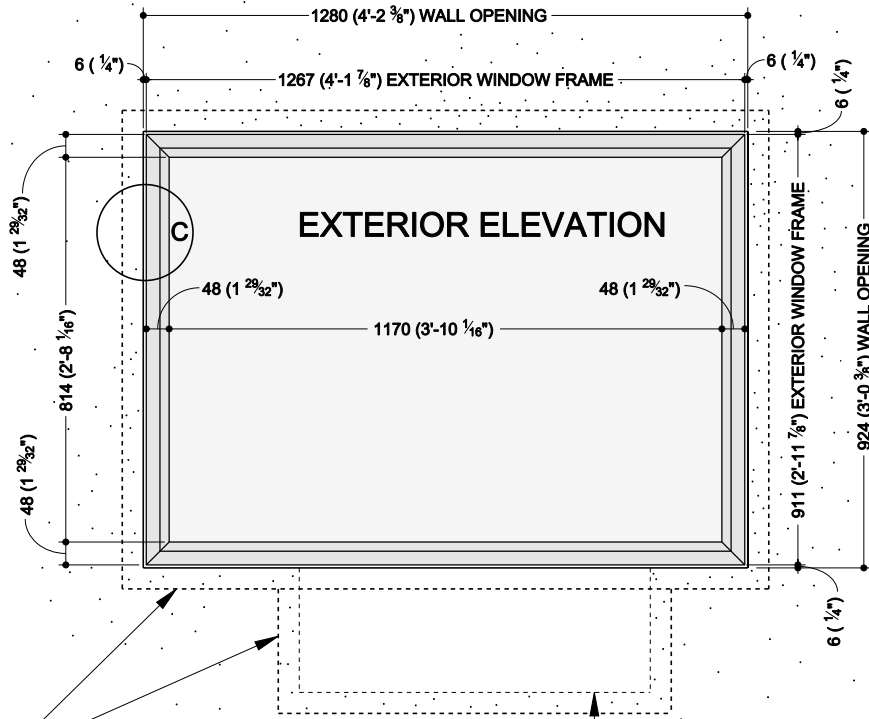
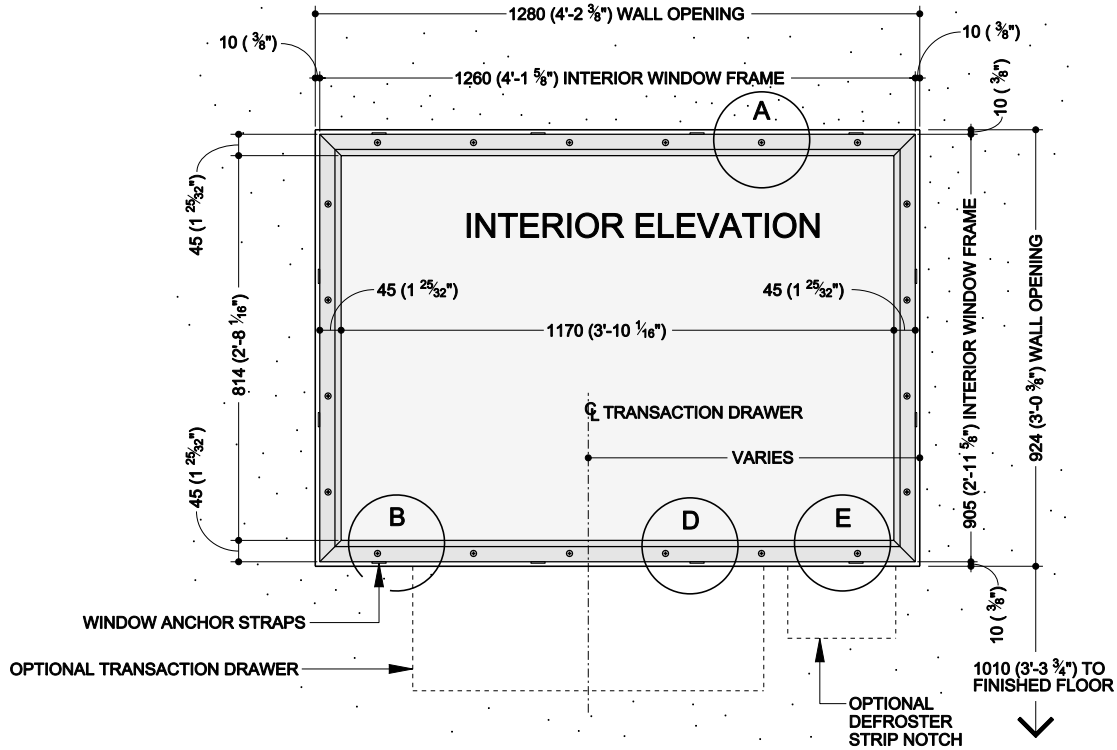

PROVIDE 44mm (1 3/4") VERTICAL AND HORIZONTAL
FLAT PLUMB SURFACE AROUND WALL OPENING
FOR PROPER INSTALLATION OF WINDOW AND
TRANSACTION DRAWER.

OPTIONAL TRANSACTION DRAWER

- 121-35 MANUAL LEVEL 1 RETAIL TRANSACTION DRAWER
- 121-36 MANUAL LEVEL 3 RETAIL TRANSACTION DRAWER
- 121-30 LARGE CAPACITY ELECTRIC TRANSACTION DRAWER (LEVEL 1)

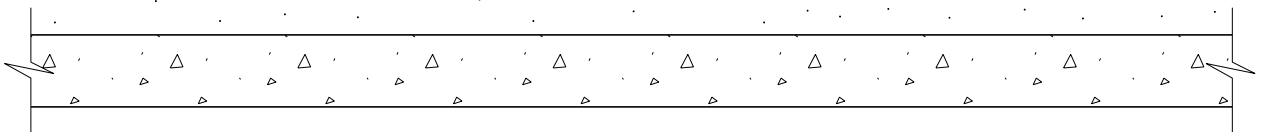

NOTE: A

HOLD 13 (1/2") (AT TOP OF WINDOW) FROM EXTERIOR WALL FINISH TO WINDOW FRAME AND 76 (3") (AT BOTTOM OF WINDOW) FROM EXTERIOR WALL FINISH TO WINDOW FRAME.

NOTE: B

FINISH AND WINDOW SILL MUST NOT COVER ANY PART OF WINDOW FRAME FLAT HEAD SCREWS.

NOTE: C

FOR SPECIFIC INFORMATION ON REGULATORY REQUIREMENTS AND CERTIFICATION, REFER TO SECTION 1.2 AND APPENDIX A OF THE 234 SERIES PRE-ASSEMBLED FIXED WINDOW INSTALLATION AND PARTS MANUAL (TP-821324-000A). THESE SECTIONS ADDRESS SPECIFIC HURRICANE INSTALLATION REQUIREMENTS SUCH AS MINIMUM NUMBER OF FASTENERS, FASTENER SIZE, TYPE, SPACING, ETC.

* CAULK CONTINUOUS AROUND FRAME BY OWNER'S G.C.

MINIMUM WALL THICKNESS:
 • 229 (9") FOR WOOD OR METAL STUD WALLS
 • 260 (10 1/4") FOR MASONRY WALLS

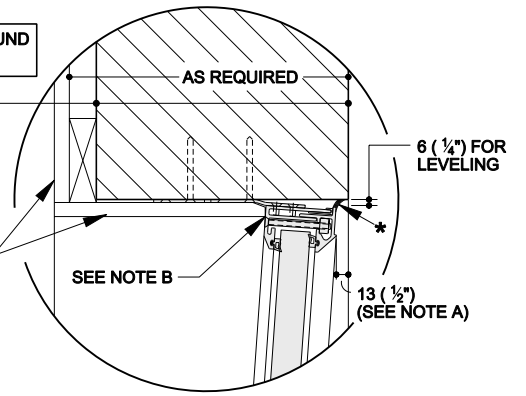

DETAIL "A"

SPECIFICATIONS:

FINISH:

- INTERIOR — BLACK POWDER COAT
- EXTERIOR — BLACK POWDER COAT

GLASS:

- LEVEL ONE - MEDIUM POWER SMALL ARMS

OPTIONAL EXTRAS FOR WINDOW

- B.R. GLASS COLORS: GRAY GREEN SOLAR BRONZE
- COUNTERTOP HEAT
- DEFROSTER STRIP
- LIGHT FIXTURE
- SHADE BOX:
- 121-35 MANUAL LEVEL 1 RETAIL TRANSACTION DRAWER
- 121-36 MANUAL LEVEL 3 RETAIL TRANSACTION DRAWER
- 121-30 LARGE CAPACITY ELECTRIC TRANSACTION DRAWER (LEVEL 1)
- 134-44A ONE ON ONE 816 AUDIO SYSTEM REQUIRED ONLY WHEN NO VACUUM AIR TUBE UNITS (VATS) ARE ORDERED WITH TRANSACTION DRAWER

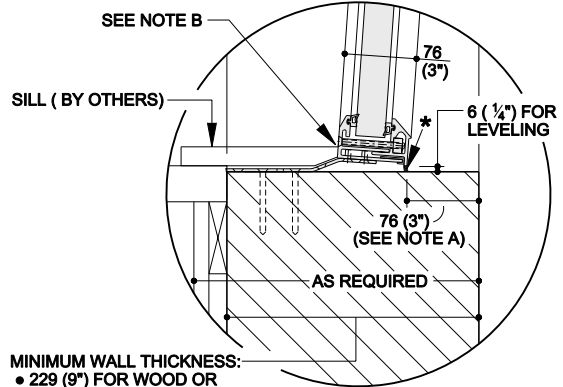

DETAIL "B"

MINIMUM WALL THICKNESS:
 • 229 (9") FOR WOOD OR METAL STUD WALLS
 • 260 (10 1/4") FOR MASONRY WALLS

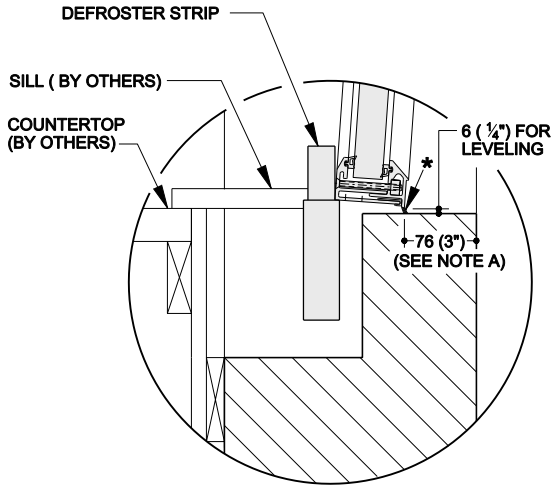

DETAIL "E"

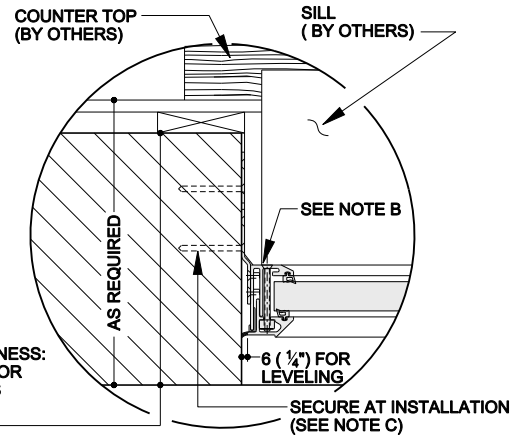

DETAIL "C"

MINIMUM WALL THICKNESS:
 • 229 (9") FOR WOOD OR METAL STUD WALLS
 • 260 (10 1/4") FOR MASONRY WALLS

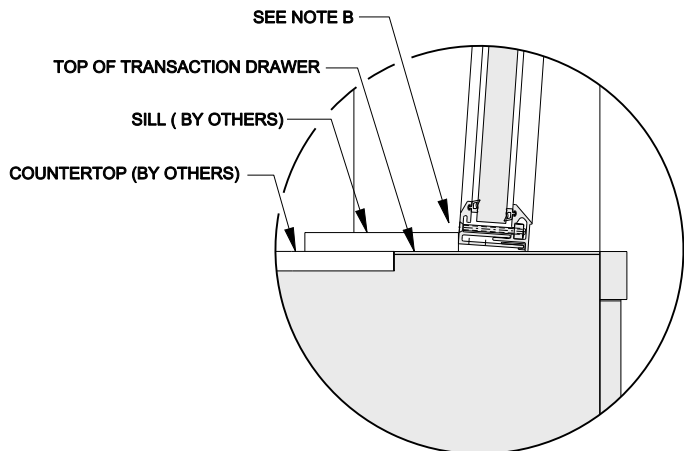

DETAIL "D"

DIMENSIONS IN MILLIMETRES (DIMENSIONS IN FEET-INCHES)

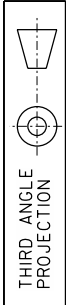

CALL 1-800-999-3600

WINDOW OPTIONS

FOR DETAILS ON THE WINDOW OPTIONS, SEE APPROPRIATE CUT SHEET

- DEFROSTER STRIP:
SEE CUT SHEET FILE NO. 178-2041
- LIGHT FIXTURE:
SEE CUT SHEET FILE NO. 178-2042
- SHADE BOX:
SEE CUT SHEET FILE NO. 178-2043
- COUNTERTOP HEAT:
SEE CUT SHEET FILE NO. 178-2044
- #121-35 MANUAL LEVEL 1 RETAIL TRANSACTION DRAWER:
SEE CUT SHEET FILE NO. 178-1951
- #121-36 MANUAL LEVEL 3 RETAIL TRANSACTION DRAWER:
SEE CUT SHEET FILE NO. 178-1951
- #121-30 LARGE CAPACITY ELECTRIC TRANSACTION DRAWER (LEVEL 1):
SEE CUT SHEET FILE NO. 178-1942

NOTE:

DIMENSION FOR LOCATING TRANSACTION DRAWER MAY VARY WITH UNDERCOUNTER EQUIPMENT ARRANGEMENT. TRANSACTION DRAWER AND UNDERCOUNTER EQUIPMENT SHOULD BE CENTERED ON WINDOW IF POSSIBLE.

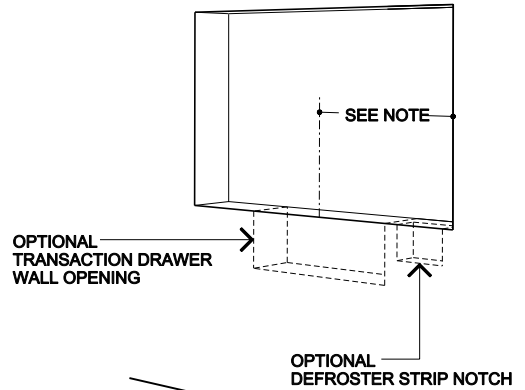

INTERIOR PERSPECTIVE

DIMENSIONS IN MILLIMETRES
(DIMENSIONS IN FEET-INCHES)

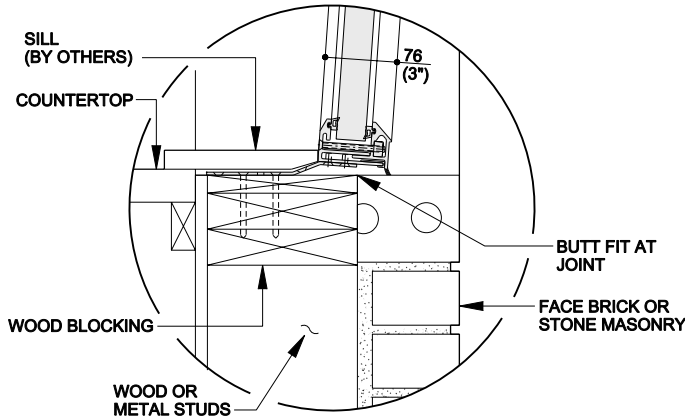

TYPICAL MASONRY VENEER INSTALLATION

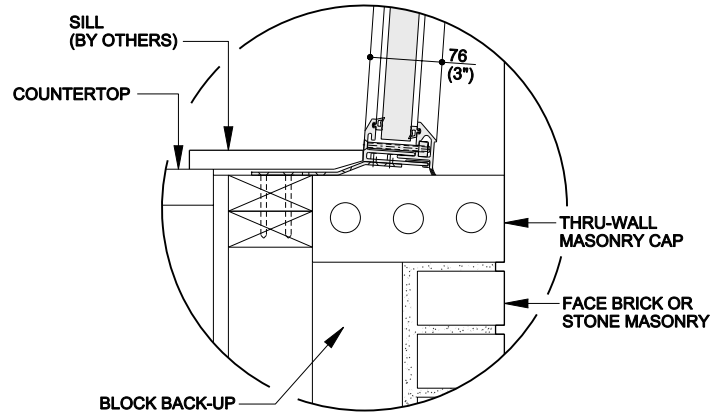

TYPICAL MASONRY INSTALLATION

(A) SECTION OF WALL OPENING AND WINDOW
ROADWAY SHOWN AT SAME LEVEL AS INSIDE FLOOR LEVEL

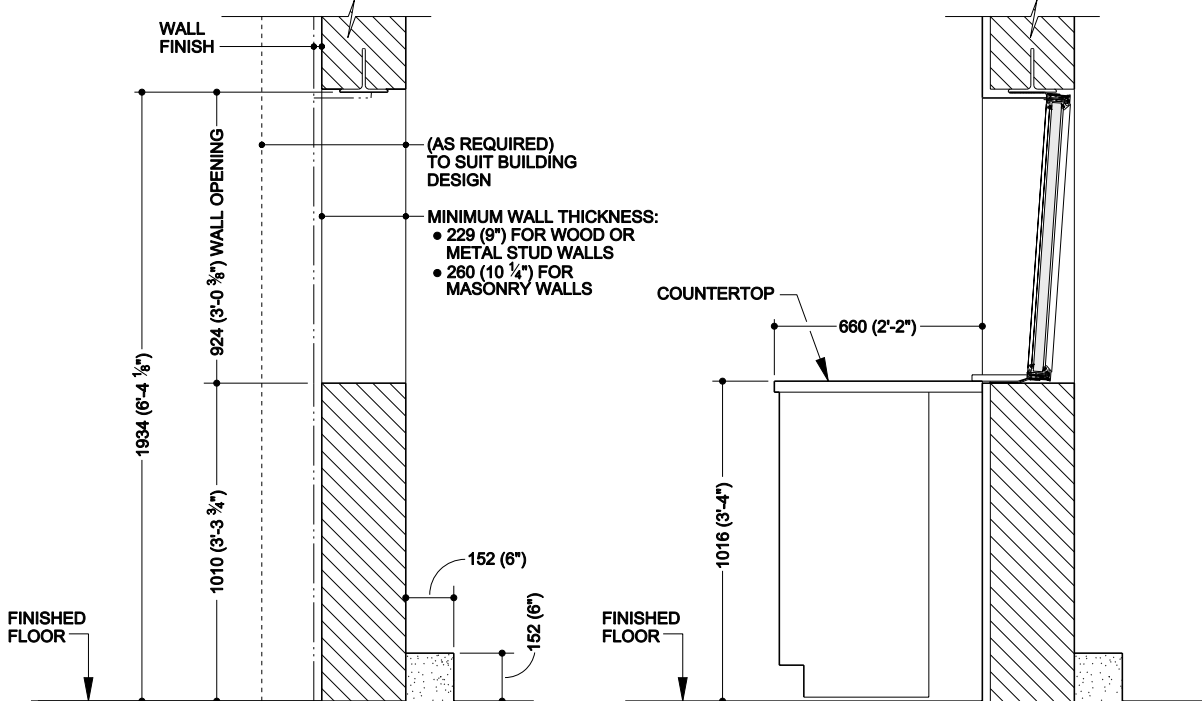

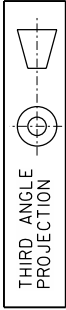

(A) SECTION OF WALL OPENING AND WINDOW

ROADWAY SHOWN 152mm (6") LOWER THAN INSIDE FLOOR LEVEL (RECOMMENDED NEW CONSTRUCTION METHOD)

