

DIMENSIONS IN MILLIMETRES  
(DIMENSIONS IN INCHES)

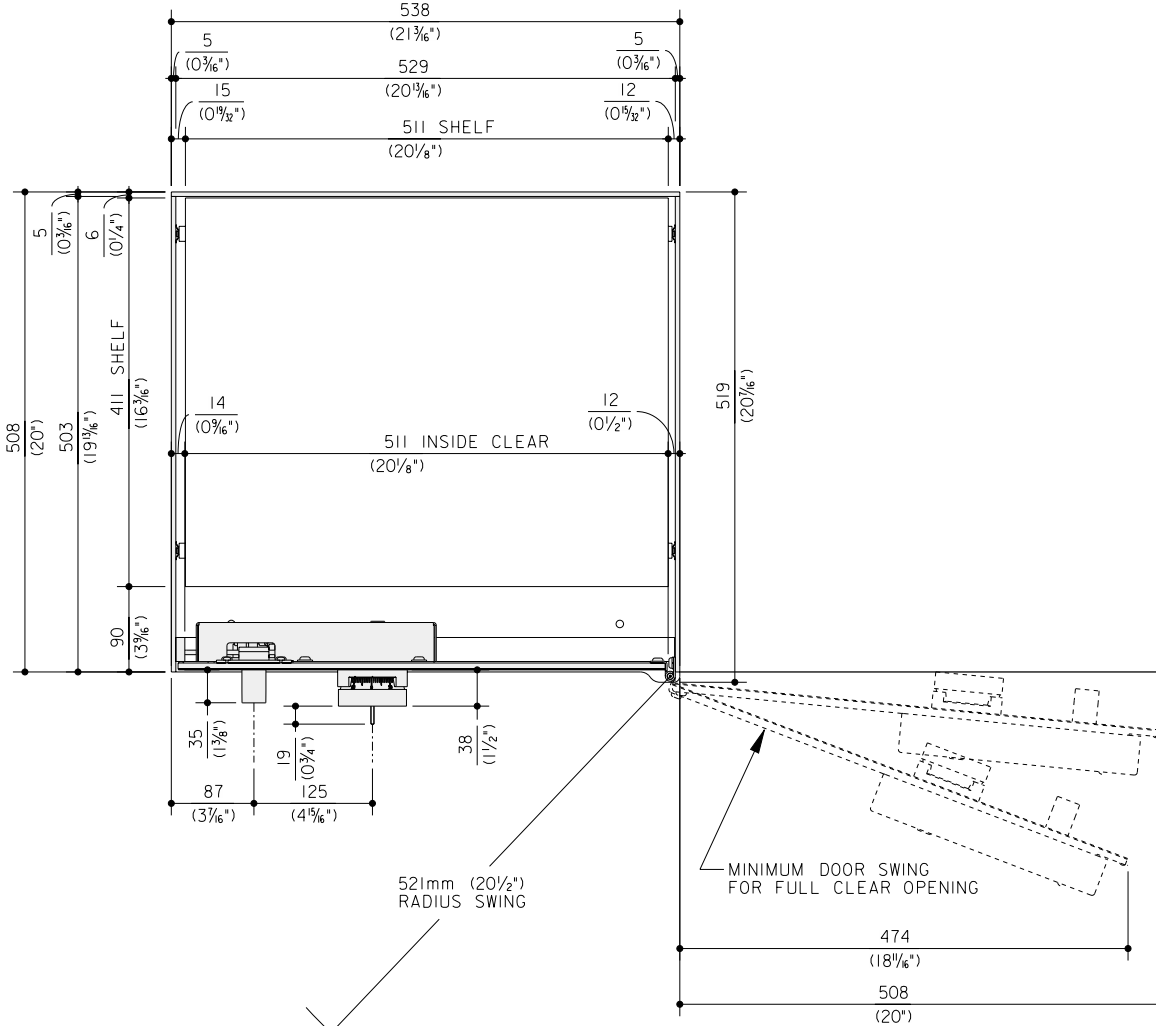

PLAN VIEW

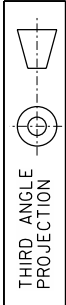
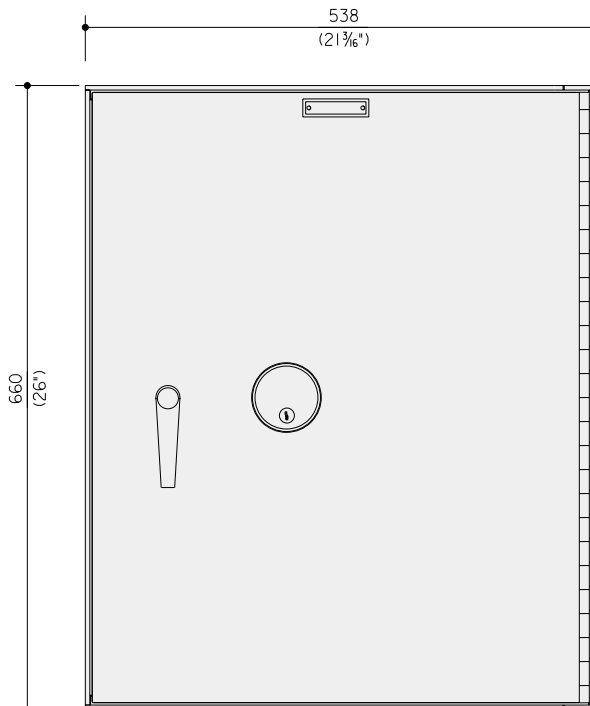

FRONT VIEW

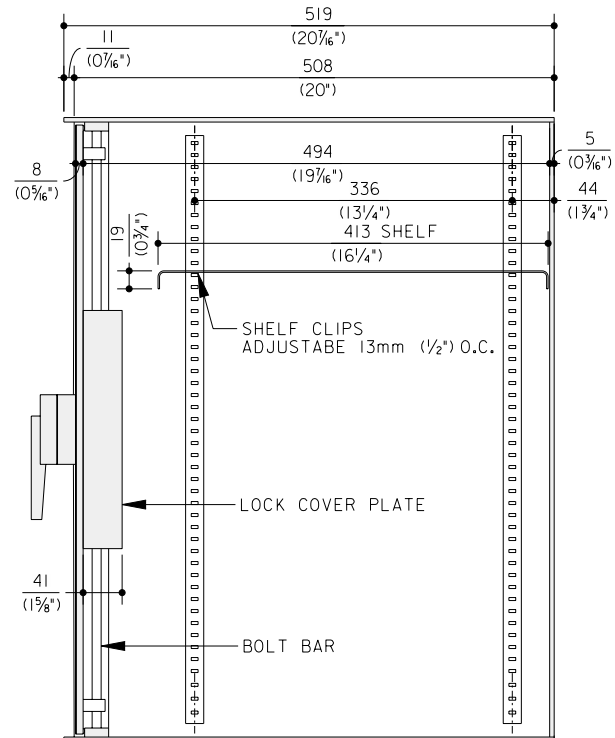

SECTION

