

DIMENSIONS IN FEET-INCHES
(DIMENSIONS IN METRES)

THIRD ANGLE
PROJECTION

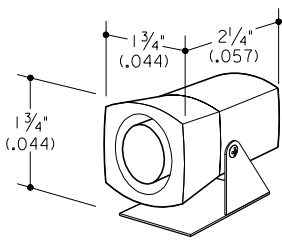

MICRO SIREN
(19-041905-000A)

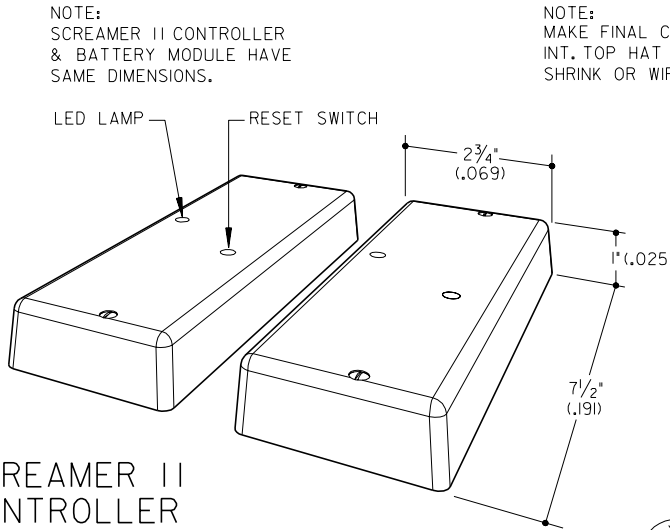

**SCREAMER II
CONTROLLER**
(19-041903-000A)

**SCREAMER II
BATTERY MODULE**
(19-041904-000A)

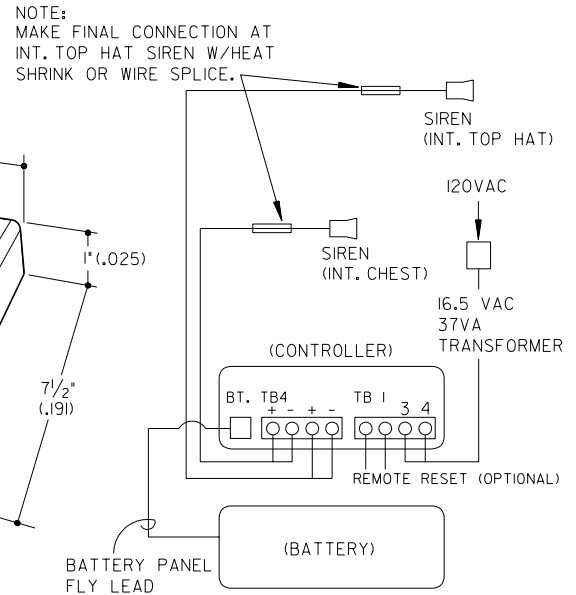

CONNECTION DIAGRAM

SPECIFICATIONS

ENCLOSURE:

- SCREAMER CONTROLLER _____ BEIGE PLASTIC
- BATTERY MODULE _____ BEIGE PLASTIC
- MICRO SIREN _____ BLACK PLASTIC

POWER:

- MAIN _____ 16-18 VAC, 37VA TRANSFORMER
- BACKUP _____ 12VDC 0.55AH RECHARGEABLE BATTERY
- MICRO SIREN OUTPUT _____ 102 DB YELP

CAUTION:

USE PROTECTIVE EAR PROTECTION WHEN INSTALLING THE SCREAMER II ALARM SYSTEM.

NOTE: THE SCREAMER CONTROLLER UNIT MAY BE RESET BY PLACING A SMALL SCREWDRIVER THROUGH THE LOWER HOLE IN THE SCREAMER'S FRONT PANEL COVER AND DEPRESSING THE MOMENTARY SWITCH.

REMOVE THE FRONT PANEL COVER FROM THE SCREAMER CONTROL BOARD AND CONNECT THE POWER SUPPLY, BATTERY AND WIRES ROUTED TO THE SIREN(S) LOCATIONS. **DO NOT** CONNECT THE SIRENS AT THIS TIME BUT ONLY INSTALL THE WIRES REQUIRED TO ROUTE TO THE SIREN LOCATIONS. CAREFULLY ROUTE THE BATTERY WIRES, TRANSFORMER WIRES AND THE SIREN WIRES THROUGH THE KNOCK OUT SIDE HOLE ON THE SCREAMER FRONT PANEL ASSEMBLY AND THEN REINSTALL IT TO THE ALARM ASSEMBLY. APPLY A SIX INCH SECTION OF THE DOUBLE SIDED TAPE (SUPPLIED) TO THE BOTTOM OF THE SCREAMER II CONTROLLER AND BATTERY ASSEMBLY. **NOTE:** PREP AREA PRIOR TO MOUNTING DOUBLE SIDED TAPE.

MOUNT THE SCREAMER II UNIT PER THE DRAWING DIMENSIONS. WHEN MOUNTING THE SCREAMER INSIDE A 1064 REAR LOAD, FOLLOW THE SAME DIMENSIONS FROM THE DOOR POSITIONING AND OPENING. ENSURE THAT THE SCREAMER CONTROLLER, AND SIREN DOES NOT OBSTRUCT ANY MECHANICAL DEVICES. ONCE CORRECTLY MOUNTED, CONNECT THE SIRENS TO THE PREVIOUSLY ROUTED WIRE FROM THE SCREAMER ASSEMBLY. IF THE SCREAMER ENERGIZES THE SIREN, INSERT A SMALL SCREWDRIVER INTO THE RESET HOLE ON THE SCREAMER ASSEMBLY (BOTTOM HOLE ON THE COVER). OBSERVE THE LED LAMP IN THE TOP HOLE OF THE SCREAMER CONTROLLER FRONT PANEL (THIS MAY BE DIFFICULT TO SEE ONCE MOUNTED) IT SHOULD REMAIN ON AT ALL TIMES.

