

PLAN VIEW

PERSPECTIVE

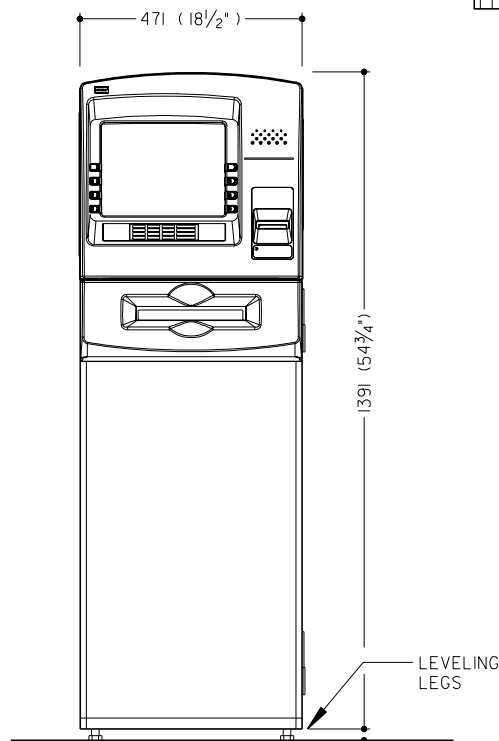

0mm (WITHOUT LEVELING LEGS) TO 21mm MAXIMUM ADJUSTMENT (0" TO 7/8")

FRONT VIEW

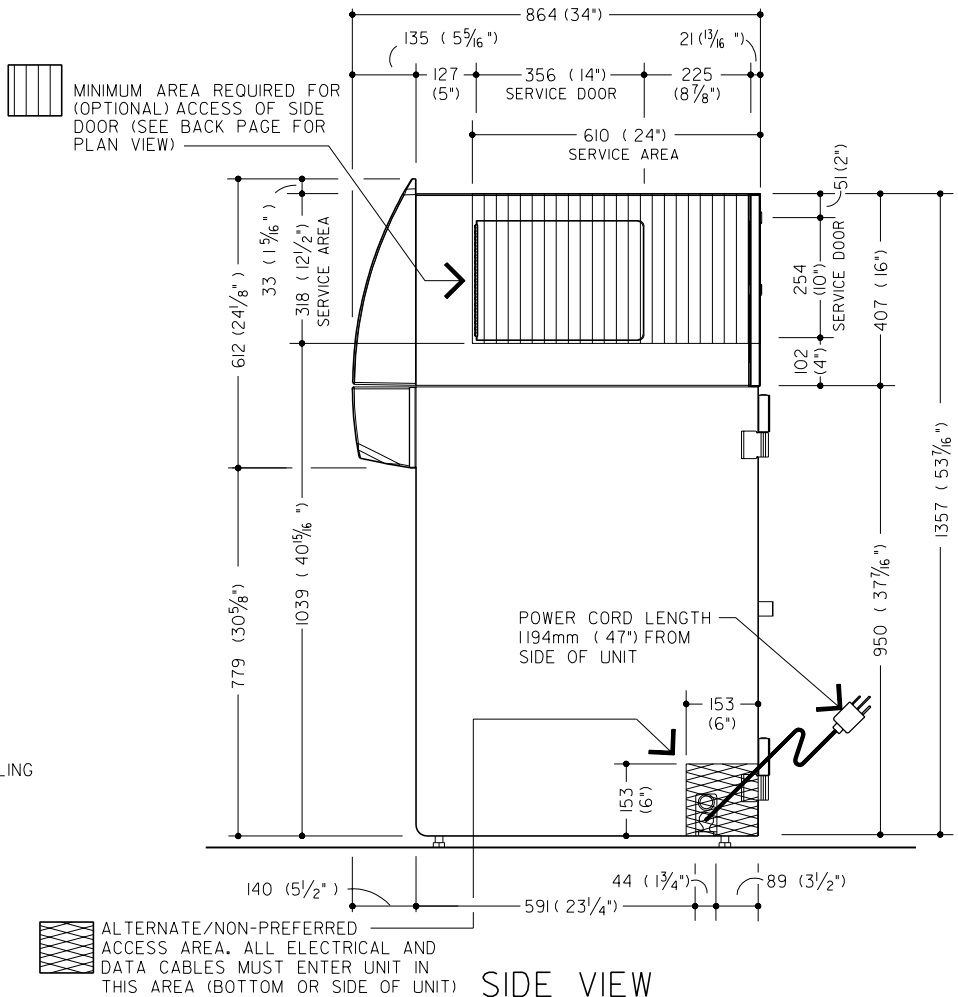

SIDE VIEW

CONDUIT AND JUNCTION BOX REQUIREMENTS

- ① 25 mm (1") METAL CONDUIT FROM ALARM CONTROL CABINET JUNCTION BOX TO 102 mm (4") SQ. X 54 mm (2 1/8") DP. JUNCTION BOX (ALL BY E.C.) DIEBOLT TO PROVIDE FLAT COVER WITH TAMPER SWITCH.
- ② WHEN "SECUROMATIC" AFTER HOUR DEPOSITORY IS TO BE CONNECTED TO ATM UNIT, E.C. TO RUN 19 mm (3/4") METAL CONDUIT FROM 102 mm (4") SQ. X 54 mm (2 1/8") DP. JUNCTION BOX TO AFTER HOUR DEPOSITORY.
- ③ E.C. TO RUN 19 mm (3/4") LIQUID TIGHT FLEX METAL CONDUIT OR 19 mm (3/4") RIGID CONDUIT FROM JUNCTION BOX TO CABLE CONNECTING PLATE.
- ④ 19 mm (3/4") METAL CONDUIT AND UNSWITCHED ELECTRICAL SUPPLY TO 102 mm (4") SQ. X 54 mm (2 1/8") DP. JUNCTION BOX WITH RECEPTACLE WITHIN 1778mm (70") OF SIDE OR FRONT CONNECTING PLATE. BOTTOM CONNECTION MUST BE COMPENSATED ACCORDINGLY (ALL BY E.C.) (SEE POWER REQUIREMENTS).
- ⑤ E.C. TO SUPPLY COMPATIBLE RECEPTACLE FOR COUNTRY SPECIFIC PLUG-IN CONNECTOR SUPPLIED WITH UNIT. POWER CORD LENGTH 1778mm (70") FROM SIDE OF UNIT.

FOR DESK TOP MODEMS- NO CONDUIT REQUIRED FOR DATA LINE CABLE. MODEM MUST BE INSTALLED WITHIN 12802mm (42'-0") CABLE RUN OF THE UNIT.

DATA CABLE MUST BE AT LEAST 51mm (2") FROM ANY A.C. POWER CABLE.

DESK TOP MODEMS MUST BE WITHIN 1828mm (72") OF A STANDARD, SINGLE PHASE, THREE-WIRE OUTLET.

NOTE:

JUNCTION BOXES MUST BE LOCATED WITHIN 1778mm (70") OF CONNECTING PLATE. (LENGTH OF ELECTRICAL POWER CABLE PROVIDED WITH UNIT). LOCATE IN AN EASILY ACCESSIBLE AREA.

BOXES CAN BE FLUSH MOUNTED WITH CONCEALED CONDUIT FOR NEW CONSTRUCTION OR BOXES CAN BE SURFACE MOUNTED WITH EXPOSED CONDUIT FOR EXISTING CONSTRUCTION.

SPECIFICATIONS

PHYSICAL SECURITY

THE SECURITY SAFE MEETS THE BANK PROTECTION ACT 82 STAT 295, 12 USC 882, AND MEETS THE ATTACK TEST PER UL 291-15. THE SAFE DOOR HAS A POSITIVE RELOCKING FEATURE. THE SAFE DOOR IS CONTROLLED BY A GROUP 2M COMBINATION LOCK WITH OR WITHOUT KEYLOCKING DIAL CAPABILITY OR OPTIONAL ELECTRONIC LOCK.

ALARM PROTECTION

THE UL-LISTED SAFE IS EQUIPPED WITH A BASIC ALARM SENSOR PACKAGE. THE BASIC PACKAGE INCLUDES A SAFE DOOR OPEN SWITCH, ALARM SHUNTING SWITCH, AND RATE-OF-RISE HEAT SENSOR.

POWER REQUIREMENTS

THE ATM REQUIRES A SINGLE-PHASE THREE-WIRE UNSWITCHED POWER OUTLET. WIRING TO THE ATM MUST USE A THIRD-WIRE EARTH GROUND (CONDUIT GROUND IS NOT ACCEPTABLE). THE POWER SUPPLIED MUST BE AS SPECIFIED BELOW:

100-127 VAC (+6%,-10%) 50Hz (+/-1%) SINGLE PHASE
 100-127 VAC (+6%,-10%) 60Hz (+/-1%) SINGLE PHASE
 200-240 VAC (+/-10%) 50Hz (+/-1%) SINGLE PHASE
 200-240 VAC (+/-10%) 60Hz (+/-1%) SINGLE PHASE

POWER TO THE ATM MAY BE A BRANCH OR DEDICATED SERVICE AND MUST BE PROTECTED BY A SAFETY QUICK-DISCONNECT DEVICE TO BREAK LINE VOLTAGE (SUCH AS A CIRCUIT BREAKER AT THE ELECTRICAL SERVICE PANEL). THE QUICK DISCONNECT DEVICE (OR CIRCUIT BREAKER) MUST TURN OFF THE LINE VOLTAGE AT THE AMPERAGE SPECIFIED BELOW.

100-127 VAC SERVICE, DISCONNECT AT 20 AMPERES
 200-240 VAC SERVICE, DISCONNECT AT 10 AMPERES

OTHER ELECTRONIC DEVICES SHARING POWER ON A COMMON BRANCH CIRCUIT MUST CONFORM TO THE SAME CONDUCTED INTERFERENCE STANDARDS AS THE ATM.

POWER USAGE

MACHINE STATUS	① SYSTEM CONFIGURATION
IDLE (NO TRANSACTION)	150 WATTS
TRANSACTION (DISPENSE) IN PROGRESS	250 WATTS

- ① CTP OR HTP PROCESSOR, MOTORIZED CARD READER, THERMAL CONSUMER PRINTER, DOT MATRIX JOURNAL PRINTER OR ODM, FOUR-HIGH DISPENSER, PRESIDER ALARM AND MONOCHROME OR COLOR VGA MONITOR

HEAT OUTPUT

853 BTU/HR MAX. (DISPENSE) - 512 BTU/HR (IDLE)

OPERATING ENVIRONMENT

SAFE LOCATION 10° C TO 38° C (50° F TO 100° F)
RELATIVE HUMIDITY, (NON-CONDENSING)
20 TO 80% AT 32° C (90° F),
20 TO 55% AT 38° C (100° F)

WEIGHT OF UNIT

488 kg (1,076 LBS.)

DIMENSIONS IN MILLIMETRES (DIMENSIONS IN INCHES)

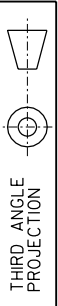

THIRD ANGLE PROJECTION

	CONSUMER KEYBOARD TOP ROW ①	CONSUMER PRINTER ②	TOP FUNCTION KEY ③	CARD READER ④	PRESENTER ⑤
HEIGHT (FROM BOTTOM OF UNIT)	1060 (41 3/4")	1207 (47 1/2")	1196 (47 1/16")	1066 (42")	876 (34 1/2")
DEPTH (FROM FRONT VERTICAL EDGE OF FASCIA)	121 (4 3/4")	40 (1 1/16")	162 (6 3/8")	24 (1 5/16")	22 (7/8")

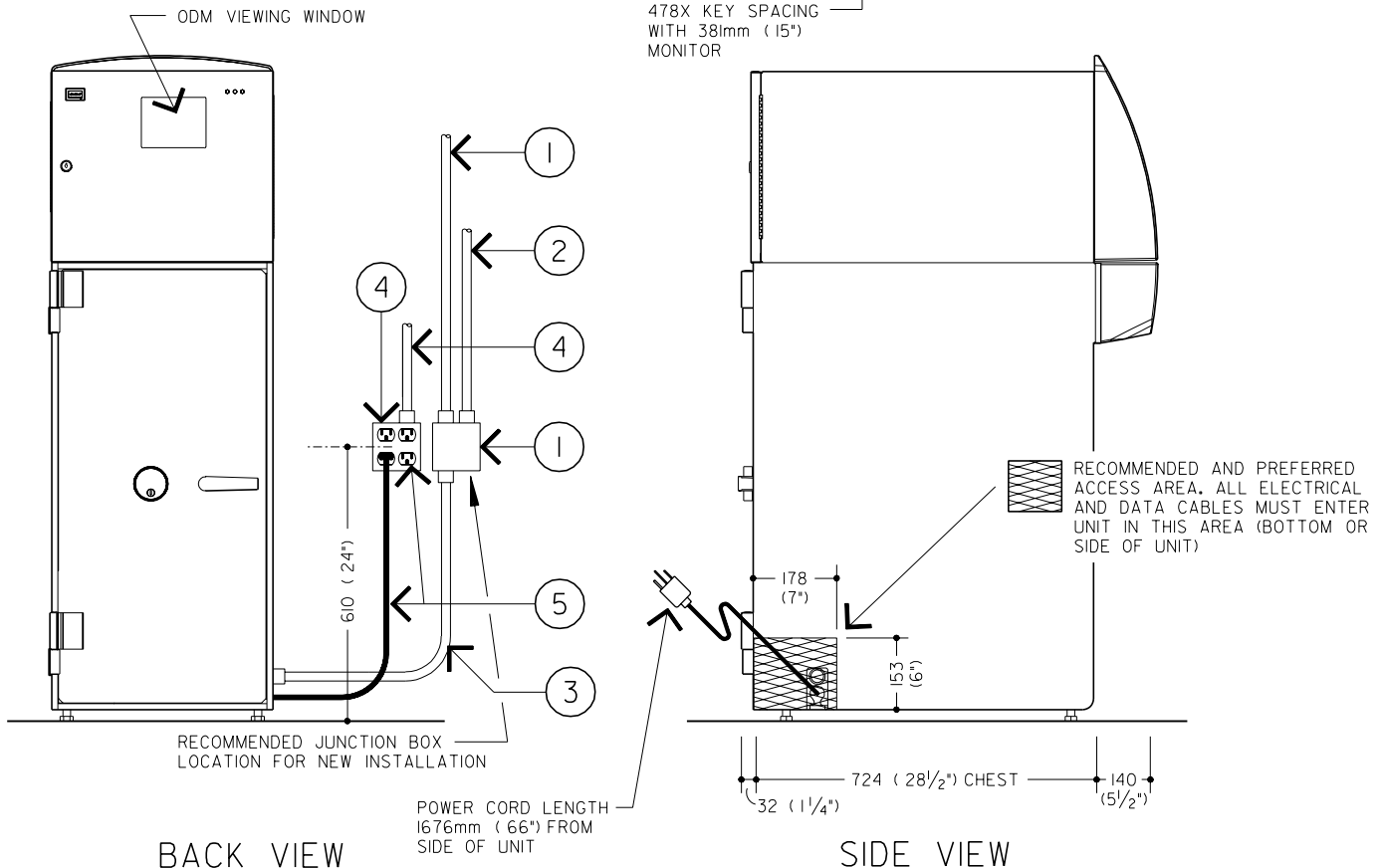

CALL 1-800-999-3600

GENERAL SPECIFICATIONS

SIGNAL CABLE RUN CONSTRAINTS

THE FOLLOWING CHART ITEMIZES THE PHYSICAL SPACING REQUIREMENTS OF THE SIGNAL CABLE RUN WITH RESPECT TO OTHER POWER AND ELECTRICAL EQUIPMENT CABLE RUN.

TYPE OF ELECTRICAL RUN	POWER OF ELECTRICAL RUN		
	BELOW 2 KVA	2-5 KVA	ABOVE 5 KVA
FLUORESCENT, NEON OR INCANDESCENT LIGHTING FIXTURES	125 mm (5")	125 mm (5")	125 mm (5")
UNSHIELDED POWER LINE OR ELECTRICAL EQUIPMENT	305 mm (12")	305 mm (12")	610 mm (24")
UNSHIELDED POWER LINES OR ELECTRICAL EQUIPMENT WITH SIGNAL CABLES ENCLOSED IN GROUNDED CONDUIT	64 mm (2½")	152 mm (6")	305 mm (12")
POWER LINES IN GROUNDED CONDUIT WITH SIGNAL CABLES IN GROUNDED CONDUIT	30 mm (¾")	76 mm (3")	152 mm (6")

SIGNAL CABLE INSTALLATION CONSTRAINTS

RELATIVE CARE IS REQUIRED WHEN INSTALLING SIGNAL CABLES IN CONDUITS. UNLIKE POWER AND LIGHTING CABLE, SIGNAL CABLES HAVE SMALL CONDUCTORS AND LIGHT INSULATION AND WILL NOT WITHSTAND AS MUCH STRAIN IN INSTALLATION. THE FOLLOWING CHART SUMMARIZES SOME COMMON CONDUIT PARAMETERS. THE SUM OF THE CROSS-SECTIONAL AREAS OF CABLES BEING INSTALLED IN CONDUIT SHOULD NOT EXCEED 40% OF THE AREA OF THE CONDUIT.

CONDUIT SIZE (INCHES)	INTERNAL DIAMETER (INCHES)	AREA-SQUARE INCHES			
		100%	40%	33%	25%
½"	.622	.30	.12	.099	.075
¾"	.824	.53	.21	.175	.132
1"	1.049	.86	.34	.283	.215
1¼"	1.380	1.50	.60	.495	.375
1½"	1.610	2.04	.81	.673	.510
2"	2.067	3.36	1.34	1.109	.840

FOR CONDUIT RUNS 15.25 METRES TO 30.5 METRES (50 TO 100 FEET), NOT MORE THAN 33% OF CONDUIT AREA SHOULD BE USED.

FOR CONDUIT RUNS OVER 30.5 METRES (100 FEET), NOT MORE THAN 25% OF CONDUIT AREA SHOULD BE USED.

EACH 90° CONDUIT BEND MAY BE ESTIMATED AS EQUAL TO THE FRICTION OF A 9.15 METRES (30 FOOT) LENGTH STRAIGHT LEVEL CONDUIT. IF MORE THAN TWO 90° BENDS ARE USED IN CONDUIT RUN, INSERT A PULL BOX.

ELECTRO STATIC DISCHARGE

STATIC ELECTRICITY CHARGES ARE BUILT-UP AS A RESULT OF CONTACT WITH CERTAIN FLOOR COVERINGS AND FURNITURE. A DISCHARGE OF THIS BUILD-UP CAN CAUSE DISCOMFORT TO PEOPLE AND POSSIBLE INTERFERENCE WITH ELECTRONIC EQUIPMENT. THE FOLLOWING PRECAUTIONS SHOULD BE TAKEN WHENEVER POSSIBLE TO REDUCE THE CHANCE OF STATIC DISCHARGE PROBLEMS.

AVOID RELATIVE HUMIDITY VALUES OF LESS THAN 40%. TREAT FLOOR COVERINGS AROUND ELECTRONIC EQUIPMENT WITH STATIC REDUCING AGENTS COMMERCIALY AVAILABLE.

EXTERNAL CABLING

PLEASE REFER TO THE APPROPRIATE ATM LITHO FOR DETAILS FOR TERMINAL CABLE ACCESS. JUNCTION BOXES, CONDUIT, ETC., ARE THE RESPONSIBILITY OF THE CUSTOMER AND ARE NOT SUPPLIED BY DIEBOLD. LOCAL CODES WILL DICTATE LOCATION AND MATERIALS TO BE USED IN ELECTRICAL CONNECTIONS.

DIMENSIONS IN MILLIMETRES (DIMENSIONS IN INCHES)



PAGE 3 OF 4

POWER/DATA CABLE PLATE

32mm (1¼") DIA. HOLE FOR POWER CORD AND DATA CABLES (SIDE ENTRY)

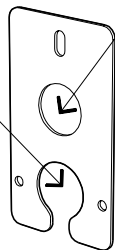

29mm (1⅛") DIA. HOLE FOR ALARM CABLES (SIDE ENTRY)

LEVELING LEGS AND FLOOR MOUNTING HOLE LOCATIONS

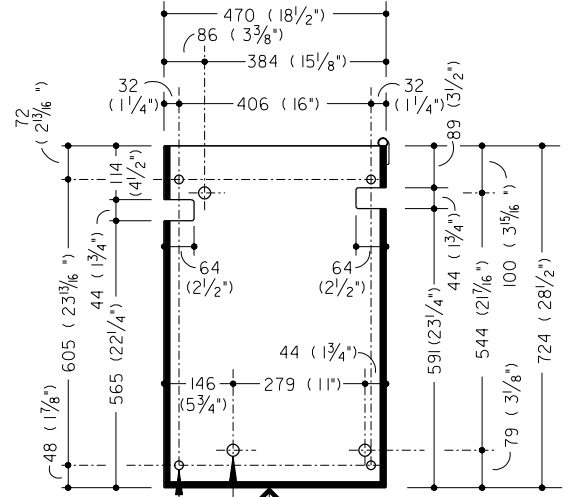

FRONT OF SAFE

(3) MOUNTING HOLES 32mm (1¼") DIA. M20 18mm (¾") BOLT RECOMMENDED FOR ANCHORING





UNIT COMES WITH (4) M16 LEVELING LEGS OR UNIT CAN BE BOLTED TO THE FLOOR
PLAN VIEW

NOTE:

ELECTRICAL AND DATA CABLING ENTERS THE ATM THROUGH A CABLE ENTRY OPENING ON THE SIDE OF THE SAFE. CABLES ENTERING THE ATM PASS THROUGH THE POWER CABLE PLATE WHICH IS ATTACHED TO THE OUTSIDE WALL OF THE SAFE OVER THE CABLE ENTRY OPENING. CABLING CAN ENTER FROM THE SIDE OR OPTIONALLY FROM UNDER THE ATM. THE RECOMMENDED CABLE ENTRY OPENING IS ON THE RIGHT SIDE OF THE SAFE AS VIEWED FROM THE REAR OF THE ATM.



SERVICE REQUIREMENTS

-  MINIMUM SERVICE AREA
-  RECOMMENDED SERVICE AREA
-  MINIMUM AREA REQUIRED FOR (OPTIONAL) ACCESS OF SIDE DOOR (SEE FRONT PAGE FOR SIDE VIEW)
-  RECOMMENDED AREA REQUIRED FOR (OPTIONAL) ACCESS OF SIDE DOOR
-  ALL ELECTRICAL AND DATA CABLES MUST ENTER UNIT IN THIS AREA (BOTTOM OR SIDE OF UNIT)

DIMENSIONS IN MILLIMETRES (DIMENSIONS IN INCHES)



TOP HOUSING SERVICE DOOR SWING (KEY LOCKED)

RECOMMENDED AND PREFERRED ACCESS AREA. ALL ELECTRICAL AND DATA CABLES MUST ENTER UNIT IN THIS AREA (BOTTOM OR SIDE OF UNIT)

CHEST DOOR SWING

ALTERNATE/NON-PREFERRED ACCESS AREA. ALL ELECTRICAL AND DATA CABLES MUST ENTER UNIT IN THIS AREA (BOTTOM OR SIDE OF UNIT)

TOP HOUSING SIDE ACCESS SERVICE DOOR SWING (RELEASE LATCH IN TOP HOUSING)

TOP CHASSIS (RELEASE IN TOP HOUSING)

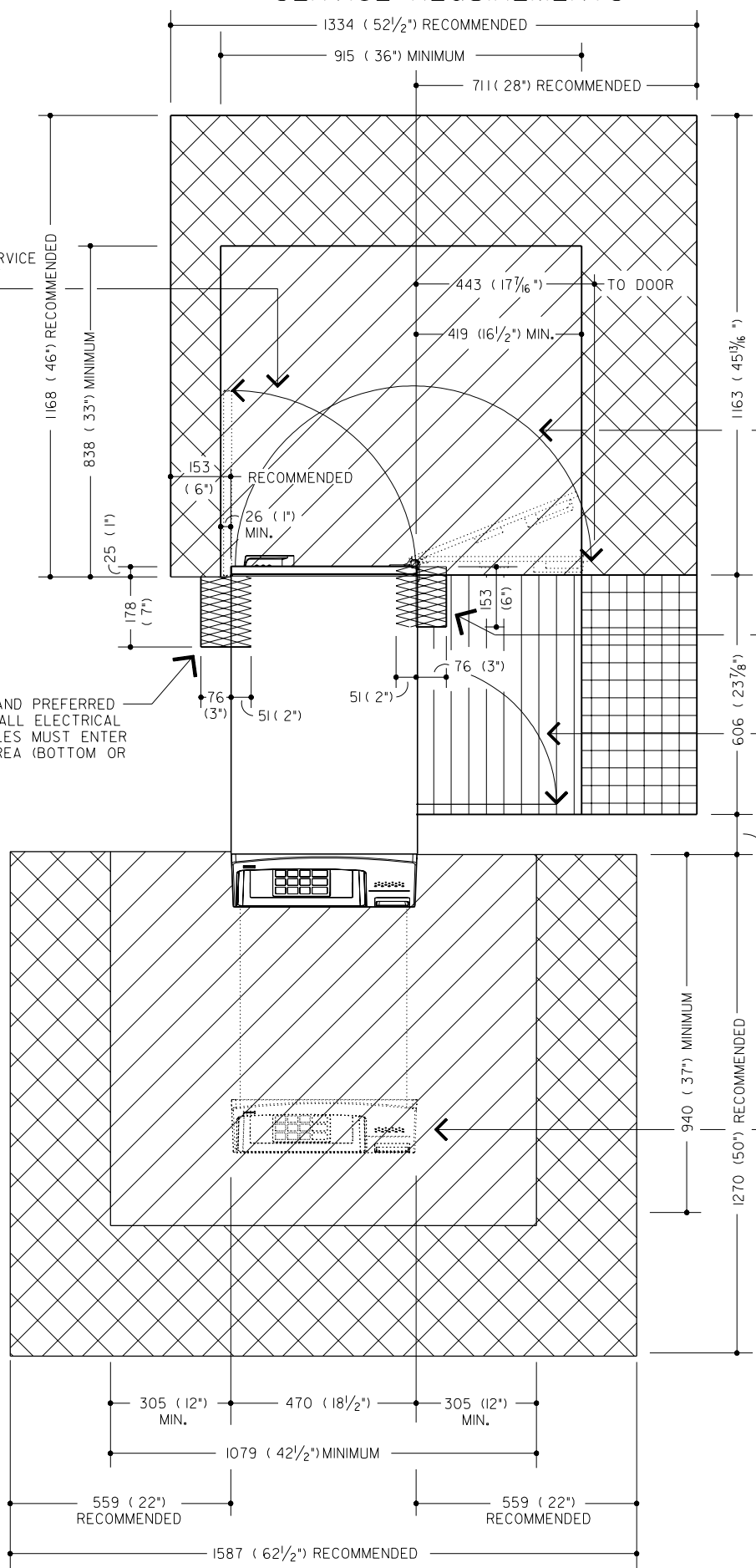

NOTE:
 THE FRONT SERVICE AREA IS REQUIRED TO ACCESS TOP CHASSIS.

PLAN VIEW